



**This Is What
Reliability
Looks Like**



Legacy Products Industry Tested and Proven

Buy New Parts Direct Or Refurbished Parts For Even More Savings



3-Way Purge Valves



Liquid Fuel Check Valves



Thermal Relief Valves

Liquid Fuel Check Valves Features

Knife edge seal to provide superior contamination tolerance preventing combustion gas blow back and fuel system evacuation.

Valve incorporates a built-in dampening feature to eliminate flow divider-induced resonant frequency oscillation resulting in more stable fuel pressure downstream of the check valve.

Material construction withstands high temperature excursions without liberating material particles and clogging critical fuel nozzle passages during subsequent flow of fuel.

Purge Air Check Valves Features

Superior sealing capability while providing low pressure drop characteristics.

Design uses Compressor Discharge Pressure to enhance sealing capability even after exposure to particulate contamination.

Material construction withstands high temperature excursions without liberating material particles and clogging critical fuel nozzle passages during subsequent flow of fuel.

Enhanced Performance Hardware

Second generation designs offer significantly improved fuel system performance due to the reduction of diesel carbonization on valve internal components.



Water Cooled 3-Way Purge Valves



Water Cooled Liquid Fuel Check Valves



Purge Air Check Valves



Water Injection Check Valves

Maximum Reliability

Water Cooling Technology Provides Increased Operating Intervals Between Liquid Fuel Runs



Water Cooled 3-Way Purge and Water Cooled Liquid Fuel Valves

Water cooled fuel controls utilized to negate the impact of coke formation and maintain ANSI class 6 sealing in the checked direction.



Heatsink Clamps

JASC Heat Sink Clamps keep fuel lines cool, reduce annual fuel costs, improve transfer and start reliably on liquid fuel, and minimize exhaust temperature spreads and trips during liquid fuel operation.

Water Cooled 3-Way Purge Valve (right) and Water Cooled Liquid Fuel Check Valve (below) configurations shown.

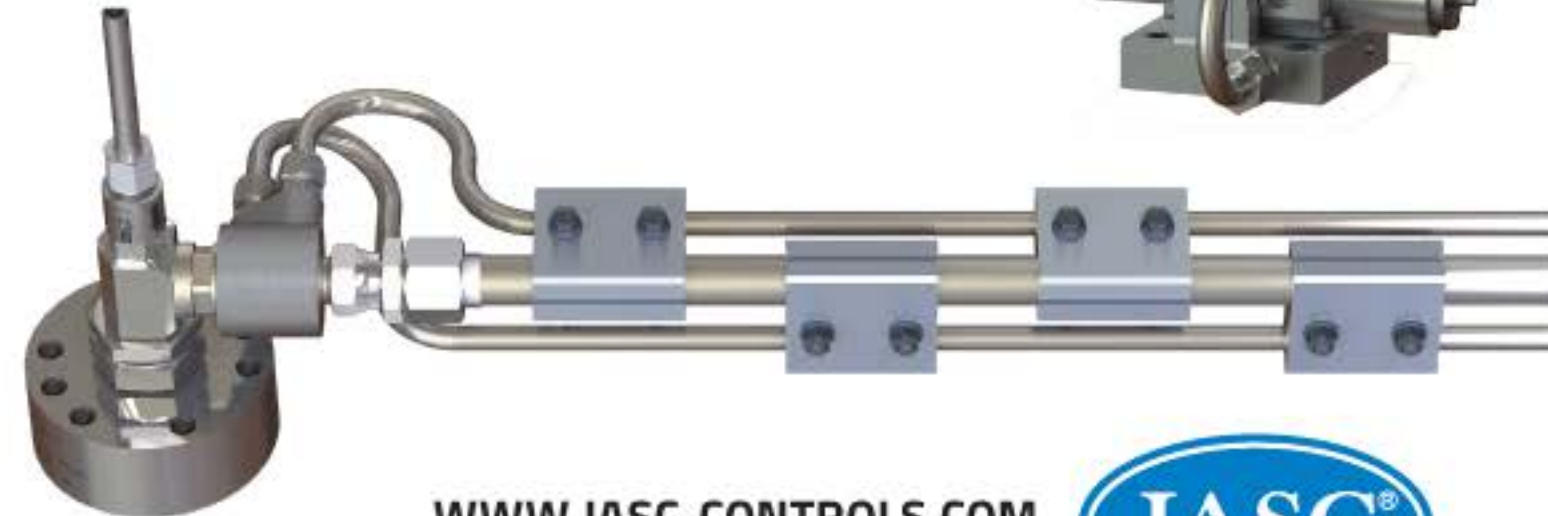

WWW.JASC-CONTROLS.COM

Tel: +1 602.438.4400 Fax: +1 602.438.4420
sales@jasc-controls.com



Frame 6B, 7EA and 9E DLN Liquid Fuel System with Fuel Distribution Valve

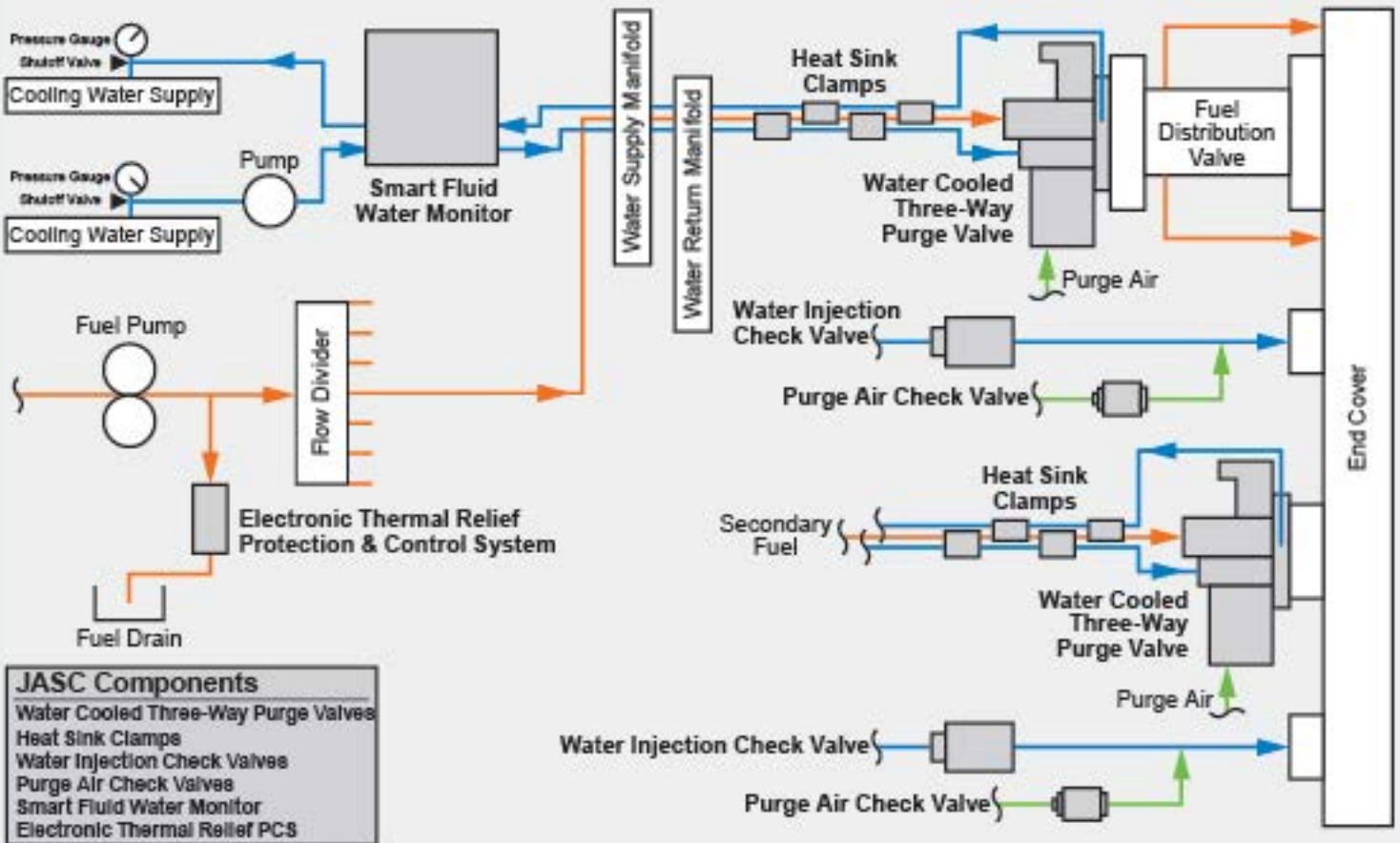

Frame 5, 6B, 7EA and 9E Liquid Fuel System with Standard Combustor

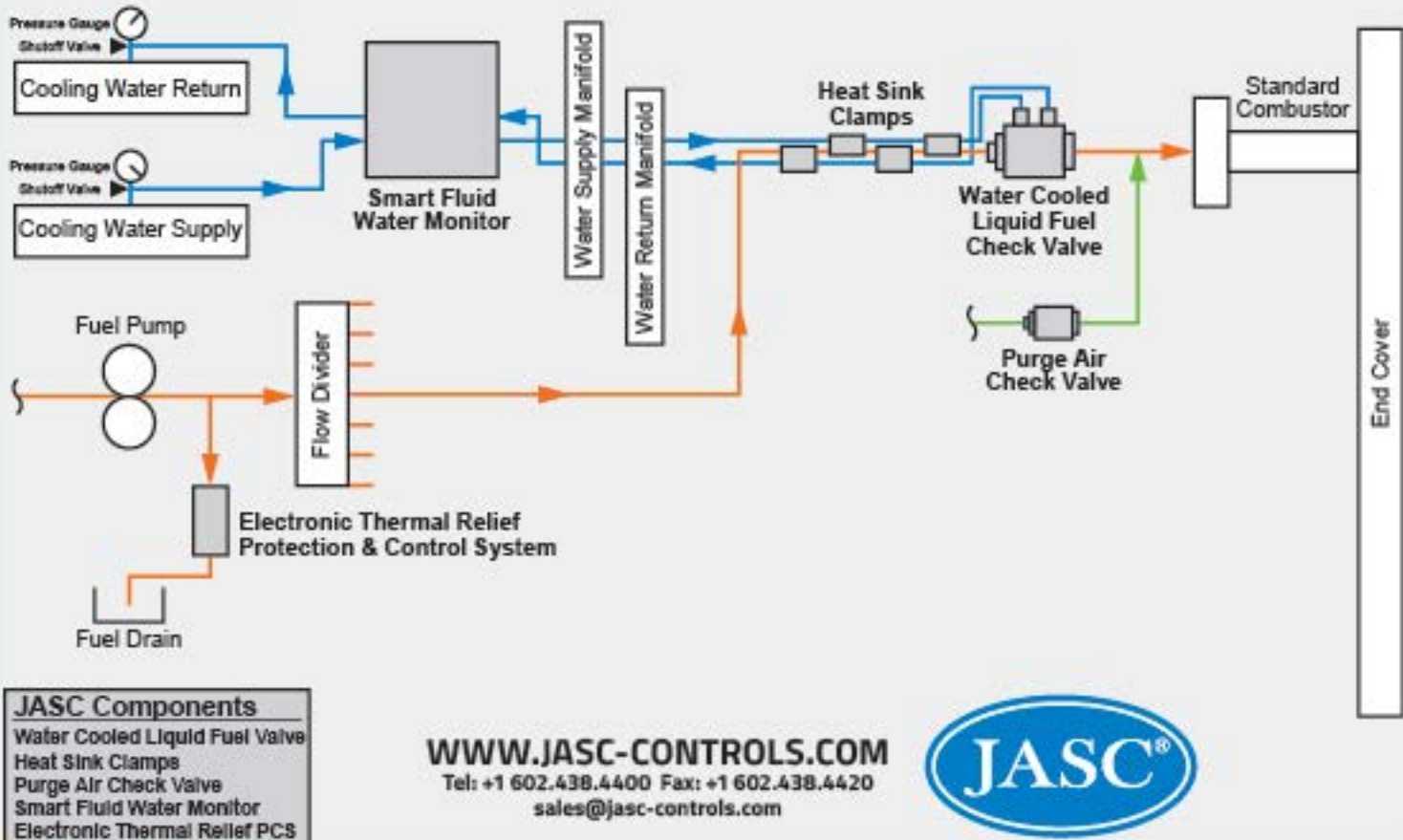

WWW.JASC-CONTROLS.COM
 Tel: +1 602.438.4400 Fax: +1 602.438.4420
 sales@jasc-controls.com

